

Hurtman Rescue

(Journeyman)

Chief Judge: CJ Schaffer

Mean Time: 4 Minutes

Drop Dead Time: 6 Minutes

Event Summary: This event simulates rescuing an injured worker from the crossarm. Looking at the pole from the crossarm side, the handline will be hanging on the right-side simulating injury to a right-handed worker. The mannequin will be hanging on the crossarm side of the pole with both ends of the safety through the braces. There will be a neutral installed on the pole.

Event Description:

1. The climber's tools will be an arm's length away from the pole. The fall arrest device cannot be placed on the pole.
2. Time starts at the judge's signal.
3. Climber must wear rubber gloves ground to ground.
4. Always take a minimum of one complete wrap around the crossarm before lowering the hurt man.
5. The mannequin should be tied under the arms with 3 half hitches (eye splice should not be used as part of the hitches). The half hitch is the only acceptable knot. A 3" piece of conduit will be used to measure the tightness of the knot.
6. Be sure to call out "headache" loudly when you drop your handline sheave. The sheave shall be dropped in the 5' circle radius at the base of the pole.
7. A Buckingham BuckSqueeze Rescue Belt 483M will used on the mannequin. You must cut the orange 483A insert. There will be a 10-point deduction for cutting the belt in the wrong place.
8. The mannequin must be lowered smoothly to the ground without contacting the pole and with slack in the handline. (team members can assist with lowering and landing the mannequin).
9. Only 1 climber will be required to rescue the mannequin.
10. Time will stop when mannequin is laid flat on the ground with slack in the line.



OVERHEAD DISTRIBUTION STANDARDS

DRAWING: TC-2
PAGE: 18-5
DATE: 1-29-14

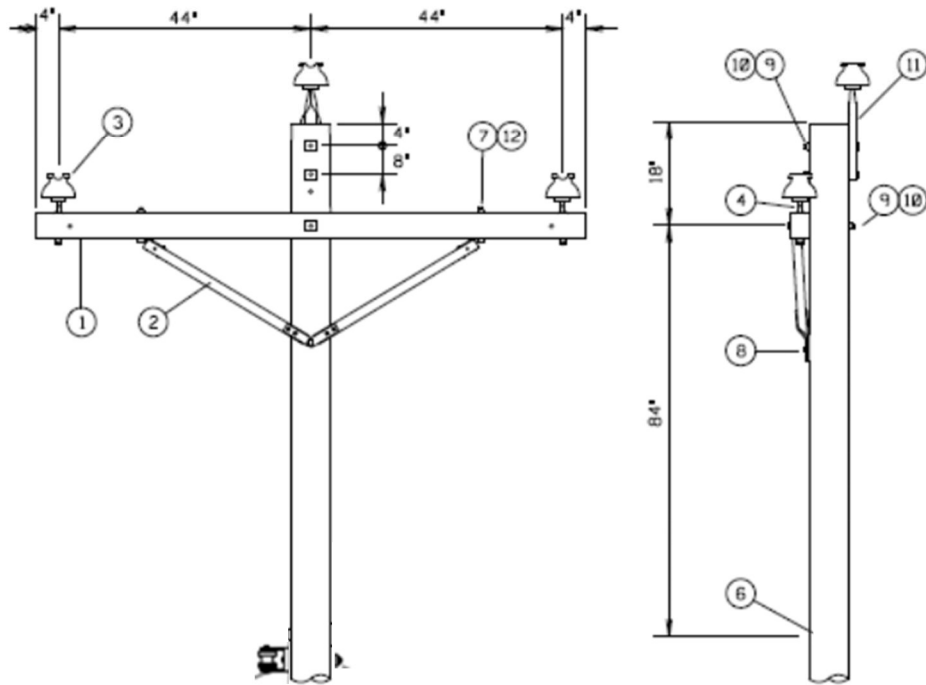

NOTES:
A. GROUNDING DETAILS CAN BE FOUND IN THE GROUNDING SECTION OF THIS MANUAL.
B. IN COASTAL AREAS USE INSULATOR #022-220125

ITEM	QTY.	DESCRIPTION	ITEM ID NO.	ITEM	QTY.	DESCRIPTION	ITEM ID NO.
1	1	CROSSARM, 4" X 5" X 8"	562-203119	9	4	BOLT, MCH. 5/8" X REQ'D	
2	2	BRACE, WOOD CA 60'	563-209104	10	5	WASHER 2" SQ. 11/16" HOLE	070-181964
3	3	INSULATOR, PIN TYPE	022-220134	11	1	PIN, STEEL POLE TOP	072-185252
4	2	PIN, STEEL INS. 5/8" X 6 1/2"	072-185224	12	3	WASHER, 2" SQ. 7/16" HOLE	070-181961
5	1	CLEVIS, SEC.	071-229174				
6	1	INSULATOR, SEC. SPOOL	023-225102				
7	2	BOLT, MCH. 1/2" X 7"	070-181436				
8	1	SCREW, LAG 1/2" X 4 1/2"	070-181866				
						GROUNDING MATERIAL - SEE GROUNDING SECTION	
10	1-14	CORRECT LAG SCREW	TLA	TLA		SINGLE PRIMARY SUPPORT CROSSARM CONSTRUCTION TRIANGULAR SPACING THREE PHASE 7.2 / 12.47kV	
09	1-10	ADD ITEM NUMBERS	TLA	TLA			
08	7-03	POLY INSULATOR CHG	KT	JEC	SER		
07	2-98	CORRECTION	JEC	JEC	CVS		
REV	DATE	DESCRIPTION	BY	D.ENG	D.SUP		D.ENG kb

dist/ods/to-2.dgn